

STANLEY®

0.5HP 5L OIL FREE AIR COMPRESSOR



MODEL NO.
AC6511

For service, spare parts or product information,
please contact Smart Marketing Group Pty. Ltd.

AUST. 1300 660 457 N.Z. 0800 474 876

SUGGESTED APPLICATIONS

You may use most light duty air tools with this compressor. Some examples of light duty tools are:

- Ball Inflator
- Toy Inflator
- Tyre Inflator
- Mini Airbrush
- Stapler
- Combo Nailer

This light duty air compressor is NOT recommended for use with a spray gun or medium duty air tools.

CONTENTS

Section	Page
Contents	2
Suggested Applications	2
Introduction	3
Guarantee	3 – 4
General Safety Instructions	5 – 7
Electrical Information	8
Specific Safety Instructions	8
Components and Controls	9
Operating Instructions	10 – 16
Maintenance	17
Trouble Shooting	17
Parts Diagram	18
Technical Information	19
Contact Information	20

INTRODUCTION

Dear Customer,

Thank you for purchasing this compressor which has passed through our extensive quality assurance processes. Every care has been taken to ensure that it reaches you in perfect condition. However, in the unlikely event that you should experience a problem, or if you require any assistance please do not hesitate to contact us;



If you have a problem, call customer service do not return this compressor to the place of purchase.

CUSTOMER SERVICE

Australia: 1300 660 457

New Zealand: 0800 474 876

Operating times: Monday – Friday 8.30am - 5.30 pm

Australian Eastern Standard Time (AEST)

EXPRESS WARRANTY STATEMENT COMPRESSOR GROUP

You are not required to do anything to register your compressor purchase. Please attach the purchase receipt to this manual and ensure both are kept safe. We hope you enjoy your new compressor, and if you have any problems call customer service on the above phone numbers. Do not return to place of purchase.

Smart Marketing Group Pty Ltd (SMG) warrants that this compressor will be free from manufacturing faults or defects for 12 months from the date of purchase, providing original purchase receipt is kept and shown when needed and is subject to the terms and conditions below.

If a warranty fault appears within the warranty period, SMG reserves the right to replace or repair the product. In the event that SMG chooses to replace the product, this original warranty will expire at the original date. If the product includes various accessories or components, only the defective accessory or component will be replaced or repaired.

SMG reserves the right to replace defective parts of the product with parts and components of similar quality, grade and composition where an identical part or component is not available.

Products presented for repair may be replaced by refurbished products of the same type rather than being repaired. Refurbished parts may be used to repair the products.

What is covered.

- Manufacturing fault or defect.

How to claim under this warranty.

- Call customer service, phone number at the top.
- Ensure you have the following: Original purchase receipt, Model of compressor, Serial number of compressor.
- Discuss the issue.
- Customer service will advise which authorised service agent to take the compressor to provided the issue is a warranty one.
- Take compressor to authorised service agent for repair.

What is not covered.

- Commercial use of compressor.
- Use of compressor in a commercial premises.
- Damage caused by incorrect fuel or incorrectly mixed 2 stroke fuel.
- Damage or deterioration due to transport.
- Damage caused by negligence, misuse, abuse or accident or incorrect voltage and wattage.
- Any corrosion or rusting.
- Damage caused by incorrect set up and start up.
- Replacement parts due to general wear and tear.
- Compressors with serial number defacement, modification or removal.
- Compressors which have been serviced by other than an authorised SMG service agent.
- Compressors with no original purchase receipt.
- Compressors which have been on sold, not original purchaser.
- Damage due non-servicing of compressor as is required by this manual.
- Blockages / damage caused by dust, dirt, spiders webs or insects.
- Damage caused by the incorrect fitting of accessories.
- Damage caused by overloading, overworking the compressor.
- Damage to attached equipment or third party accessories.
- Damage caused by attached equipment or third party accessories.

CONTACT DETAILS

Smart Marketing Group Pty Ltd

33-35 Lionel Road, Mt. Waverley

Victoria 3149, Australia.

Tel (+613) 9543 7266

Fax (+613) 9543 9839

sales@smga.com.au

COMPLETE WARRANTY STATEMENT – COMPRESSOR GROUP

As soon as you have purchased the air compressor, we recommend that you check to make sure it is intact and that you read the operating instructions carefully before using it. The purchase receipt for this product is to be retained and must be presented if making a claim under the terms of the Smart Marketing Group (SMG) warranty. Bank account statements are not acceptable for proof of purchase.

This warranty does not cover air compressors intended for hire or use in commercial applications or in commercial premises. The warranty will under no circumstances extend to reimbursement or payment of damages, whether direct, indirect or consequential. The warranty is void if there is evidence the air compressors has been modified or tampered with in any way or used with unauthorised accessories without our consent.

SMG declines any responsibility or liability whatsoever arising from misuse or abuse, negligent handling of the air compressors or if the product has not been installed or failure to comply with the relevant safety, operating, setting and maintenance instructions (see further in this manual).

Any item sent freight collect for repair will be refused. Warranty repairs are free of charge, provided the appliance is delivered to our service department or authorised service agent. The air compressor will need to be returned, adequately protected in a box. Transit damage is responsibility of the owner. Assistance under the warranty will only be made available if the request is made to our customer service team on the contact numbers listed below and proof of purchase is provided.

This is a repair only warranty you will need to take the air compressor to the authorized service agent after contacting our customer service centre.

Damage caused by third party accessories is not covered under this warranty.

Damage caused to attached equipment or third party accessories will not be covered under this warranty.

Rust and corrosion are not covered under this warranty.

If a warranty fault is found the freight cost will be credited to the owner. Blockages caused by spider webs, insects, dirt, or accumulated dust is not covered by warranty. SMG reserves the right to replace or repair the appliance within the warranty period. Parts found to be defective due to a manufacturing default will be replaced free of charge.

In the event of SMG choosing to replace the appliance, the warranty will expire at the original date of purchase. If no warranty fault is found the owner will be advised and the product will be returned and any costs associated with the service will be charged to the owner.

In Australia, this SMG warranty is in addition to the conditions and guarantees which are mandatory as implied by the Trade Practices Act 1974 and State and Territory legislation.

In New Zealand, this SMG warranty is in addition to the conditions and guarantees which are mandatory as implied by the New Zealand Consumer Guarantee Act 1993.

For service, spare parts or product information please contact customer service:

Australia: 1300 660 457

New Zealand: 0800 474 876

LUBRICATION OF COMPRESSOR

This air compressor is OIL FREE. Therefore there is NO oil used for lubrication.

ASSEMBLY

This compressor **MUST** be fully assembled by you prior to use. Failure to do so will result in the warranty being VOID. Failure to fully assemble this compressor may also result in personal injury.

SAFETY

Before attempting to operate this air compressor the following basic safety precautions should be taken to reduce the risk of fire, electric shock and personal injury. It is important to read the instruction manual and to understand applications, limitations and potential hazards associated with the air compressor. This air compressor is not intended for use by persons (including children) with reduced physical, sensory or mental capabilities, or lack of experience and knowledge, unless they have been given supervision or instruction concerning the use of the appliance by a person responsible for their safety.

BEWARE OF CHILDREN AND PETS

Children and pets should be kept out of the work area. Children should not be allowed to touch or operate the air compressor, tools or extension cords. This air compressor is not designed for use by young children or infirm persons without supervision. The air compressor and tools should be kept out of reach of children, preferably stored or locked in a secure cabinet or room when not in use.

WORK AREA

Work areas and benches should be kept tidy. Cluttered benches and work areas can cause accidents. Floors should be kept clean and free from rubbish. Special care should be taken when the floor is slippery due to sawdust or wax. Always leave sufficient distance, at least 5 metres between the air compressor and the work area, especially when using tools designed for sanding or spraying liquids.

WORK ENVIRONMENT

Do not expose your air compressor to rain or use in damp or wet conditions. Keep the work area well lit.

GUARD AGAINST ELECTRIC SHOCK

Avoid body contact with earthed or grounded surfaces (e.g. pipes and refrigerators).

DO NOT FORCE AIR COMPRESSORS

The air compressor will do a better, safer job and give you much better service if it's used at the duty cycle for which it was designed. The duty cycle will only take effect after the initial (1st) tank fill for the day. This air compressors duty cycle is 75%. Duty cycle is the proportion of time during which the air compressor is operating compared with not operating. For example a 75% duty cycle could mean after 45 seconds of operation, motor pumping, the air compressor must be left for 15 seconds resting, motor not pumping. When the motor is pumping the attached air tool can not be used. Only use the attached air tool while the compressor is not pumping. Stop using the attached tool as soon as the air compressor starts pumping.

USE THE RIGHT TOOL

Select the right tool for the job. Do not use a tool for a job for which it was not designed. Do not force a small air compressor to do the job of a heavy-duty air compressor. Do not use the air compressor for purposes not intended.

DO NOT ABUSE THE POWER CORD

Never yank or pull on the power cord to disconnect it from the mains supply socket. Never carry or pull your air compressor by its power cord. Keep the power cord away from heat, oil, solvents and sharp edges. Regularly check the plug and cord and if damaged have it replaced by an authorised service facility.

EXTENSION CORDS AND REELS

This air compressor **MUST** be plugged directly into a 240V AC wall socket.

This air compressor is **NOT** designed to be run off an extension cord/lead. If you need extra distance do **NOT** use an extension cord, **USE A LONGER AIR HOSE**.

The use of extension cords may cause power voltage loss and will result in damage to the motor. This will **NOT** be covered under warranty.

SECURE THE WORK PIECE

Whenever possible secure the work piece using clamps or a vice. It is safer than using your hands or feet and leaves both hands free to control the tool.

HOT COMPONENTS

Beware many of the components will get hot during use. Never touch any of the metal pipes, pump or motor as these may burn.

MAINTAIN YOUR AIR COMPRESSOR WITH CARE

Follow the instructions for use and changing accessories. Check the air compressor power cord periodically and if damaged have it replaced by an authorised service facility. Keep handles clean, dry and free from oil and grease. Ensure that ventilation slots are kept clean and free from dust at all times. Blocked ventilation slots or air filter can cause overheating and damage to the motor and this will not be covered under warranty.

DISCONNECT AIR COMPRESSOR

Ensure that the air compressor is disconnected from the mains supply when not in use, before servicing, making adjustments or when changing any accessories.

REMOVE ADJUSTING KEYS AND WRENCHES

Form the habit of always checking to see that any adjusting keys or wrenches have been removed from the air compressor or attached air tools before operating.

AVOID UNINTENTIONAL STARTING

Ensure that the switch is in the 'OFF' position before plugging the air compressor into the mains supply.

PROTECT FURNISHINGS

If using the air compressor inside your house, protect furnishings and floors with a suitable dust sheet.

FIRE PRECAUTIONS

When using the air compressor inside your house or workshop general fire precautions should be observed. As a precaution it is recommended that an expert is consulted on obtaining and using a suitable fire extinguisher.

CLEANING YOUR AIR COMPRESSOR

Always disconnect your air compressor from the mains power supply before you commence cleaning. Always ensure that your air compressor has cooled, about one (1) hour, before cleaning and storing. When cleaning your air compressor use only a damp soft cloth. **NEVER** use liquid or solvents of any type.

CHECK DAMAGED PARTS

Before using the air compressor it should be carefully checked to determine that it will operate properly and perform its intended function.

Check for the correct alignment of moving parts ensuring that they do not bind. Check for broken or missing parts and have them replaced or repaired at an authorised service facility. Check any other condition that may affect the operation of the air compressor. A guard or any other part of the air compressor that is damaged should be properly repaired or replaced by an authorised service facility unless otherwise indicated in this instruction manual.

Any switch that does not operate correctly must be replaced by an authorised service facility.

DO NOT use the air compressor if the 'ON / OFF' switch does not turn the air compressor 'ON' and 'OFF'.

PERSONAL SAFETY

Clothing

Do not wear loose clothing, jewellery or anything that could get caught in moving machinery.

Hair

Long hair should be tied back or contained in a protective covering.

Eye Protection

The use of safety goggles is highly recommended (normal glasses are not sufficient for eye protection) when using an air compressor. Prescription glasses do not have safety lenses.

Footwear

Where there is the risk of heavy objects or if there is a risk of slipping on wet or slippery floors, suitable non-slip safety footwear should be worn. Protect your feet from dropping accidents.

Ear Protection

The use of ear protection is highly recommended when using air compressors. The continual noise may damage your ears.

Respiratory Protection

When operating any machinery that creates dust or when spray painting, an approved dust / filter mask must be worn. When machining concrete, man made fibres, especially MDF (Medium Density Fibre board), the resin used in these materials can be hazardous to your health. Use an approved face mask with replaceable filter.

Do Not Over Reach

Do not over reach. Keep a proper footing and maintain your balance at all times. Avoid using abnormal stances and awkward body positions.

Stay Alert

Watch what you are doing, use common sense, and never operate an air compressor when you are tired, drinking alcohol, taking drugs or if taking medication that causes drowsiness.

WARNING



Only use air compressor when fully assembled.

Do not attempt to modify the air compressor in any way; this will VOID your warranty.

The use of any attachment or accessory other than those recommended in this instruction manual could result in damage to the air compressor and could cause injuries to the operator.

This electric air compressor complies with Australian / New Zealand and International standards and safety requirements. Repairs should only be carried out by qualified persons using original spare parts. Failure to do so may result in considerable danger to the operator.

ELECTRICAL DATA



IMPORTANT

This air compressor is fitted with a sealed electrical connection plug that is compatible with the mains power supply for Australia / New Zealand and meets the requirements of Australian Standards. This air compressor must be connected to a supply voltage that is equal to that stated on the rating label. If the mains power connection plug or power cord becomes damaged it must be replaced with a complete assembly that is identical to the original, and this must be replaced by an authorised service centre. Always follow the Australian / New Zealand requirements for connection to the mains supply. If in doubt always consult a qualified electrician.

SPECIFIC SAFETY INSTRUCTIONS

Warning! Do not use the air compressor in areas where there is a risk of explosion or fire from combustible materials. The sparks generated from certain tools attached to air compressor can ignite combustible materials as well as flammable liquids, paint, varnish, petrol, flammable gases and dust of an explosive nature. As a precaution it is recommended that you consult an expert on a suitable fire extinguisher and its use.

- **Do not attempt to modify the air compressor, guards or the supplied accessories in any way.**
- **Domestic air compressors are designed for intermittent operation. Ideally a 75% duty cycle. (Meaning, 45 seconds ON motor pumping and 15 seconds OFF, motor not pumping). When the motor is pumping the attached air tool can not be used. Only use the attached air tool while the compressor is not pumping.**
- **Stop using the attached tool as soon as the air compressor starts pumping.**
- **Fully assemble compressor before use.**
- **Always ensure your compressor is level and stable.**
- **Never use an extension cord with this compressor always use a longer air hose.**
- **Never connect to a generator which does not produce sufficient**

power, at least 800W and has pure sine wave power output.

- Domestic air compressors are not designed for industrial / commercial applications.
- Domestic air compressors are not designed for continuous running.
- Avoid touching the pump area as it can become very hot and may burn.
- Ensure that the air compressor is disconnected from the mains supply when not in use, before servicing, making changes and when changing attachments such as air hoses / tools.
- Always use the correct type of tool for the operation to be carried out.
- Never use the air compressor if any part of the unit is damaged. Always have the air compressor serviced by an authorised service agent.
- Always wear safety eye, ear and respiratory protection when operating the air compressor.
- Allow the tank to completely fill before using the air compressor.
- If the air compressor makes an unfamiliar sound or vibrates excessively, switch the air compressor 'OFF' immediately and disconnect from the mains power supply. Investigate the possible cause or consult your authorised service facility.
- Always move the air compressor using the handle and wheels.
- Always use the air compressor on stable ground.
- This air compressor is designed to compress normal air. Never use to compress any other type (s) of gases.
- Never direct the jet of air or other liquids / gases towards your body, other persons or animals.
- Never direct the jet of air or other liquids / gases towards this air compressor.
- This air compressor is not suitable for pharmaceutical, food or sanitary purposes.
- This air compressor is not to be used to for filling scuba or oxygen air bottles or tanks.
- Always follow the instructions relating to the tools attached to this air compressor.

PIC. 1



COMPONENTS AND CONTROLS

Pic. 1

1. Regulator
2. Outlet pressure gauge - large
3. On / Off switch
4. Tank pressure gauge - small
5. Handle
6. Tank
7. Rubber feet
8. Tank drain valve
9. 'Nitto style' outlet socket
10. Tidy clips for powercord
11. 2pc Wall bracket and 2 hex headbolts (not shown)
12. 1pc Allen key (not shown)

OPERATING INSTRUCTIONS

Unpacking

Carefully unpack your air compressor. Dispose of all packing material in an environmentally responsible manner.

Assembly

Your air compressor requires minor assembly before initial operation. Check that you have all required components required for assembly and initial use.

ATTACHING BRACKET TO COMPRESSOR

Pic. 2 & 3

1. Install the smaller of the 2 brackets onto the rear of the compressor.
2. Using the hex head bolts provided securely attach the wall bracket to the compressor.

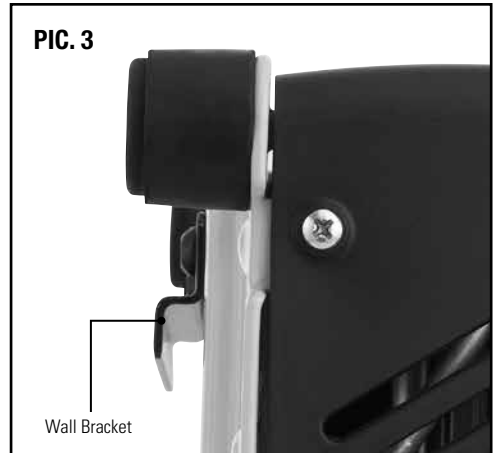
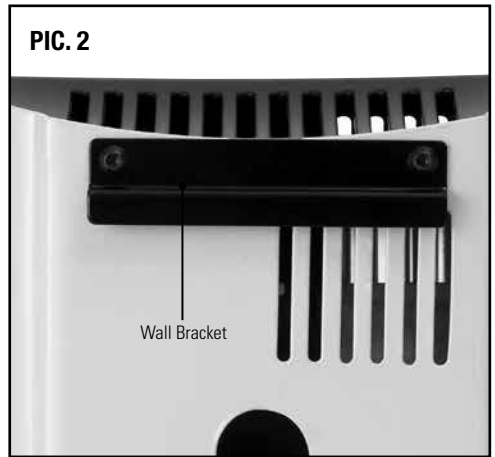

WARNING

Do not attempt to operate this compressor until it is fully assembled.

Damage caused due to incomplete assembly will not be covered under warranty.

Ensure the air compressor is disconnected from the power supply before carrying out any assembly, maintenance or adjustments on the machine.

ATTACHING COMPRESSOR TO WALL

1. Select a suitable location, not in a walkway.
2. Using the large wall bracket as a template mark and drill two mounting holes.
3. Using two suitable screws (not supplied) attach the wall bracket to the wall, Pic. 4.
Note: If unsure of what screws to use please discuss with your local hardware store.
4. Clip the compressor into place and ensure that compressor is located fully before allowing to hang, Pic. 5.

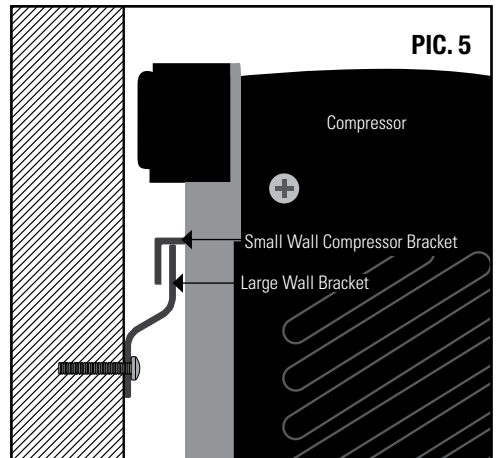
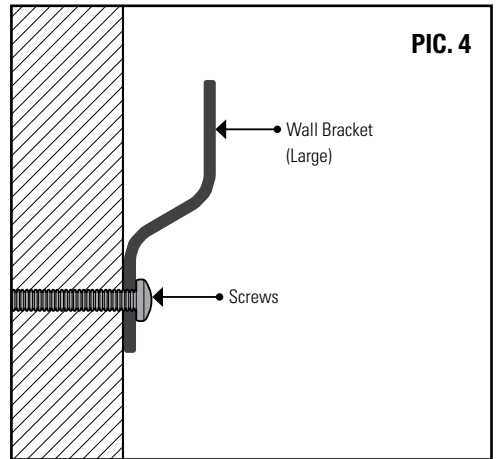

CAUTION

When drilling, take care to avoid any electrical wiring, gas or water pipes located in or behind the wall.

Safety glasses should be worn anytime a drill is being used.

If unsure what type of wall screw and wall plug to use. Please see your local hardware store for assistance.

STARTING AND STOPPING YOUR AIR COMPRESSOR

Pic. 6

NOTE: Always ensure that you plug your air compressor into a standard 240V AC power point. Never use an extension cord as this can lead to a voltage drop which may cause power loss and over heating. Use a longer air hose if you need to get closer to your work area.

Always start and stop the compressor using the ON/OFF switch on the Compressor (Pic. 6). Damage caused by not using this switch will not be covered by warranty.

To turn your air compressor ON;

Push switch to **I** for on. Switch will glow red.

To turn your air compressor OFF;

Push switch to **O** for off.



RUNNING IN YOUR NEW AIR COMPRESSOR

Your new air compressor does not require running in:

This compressor is ready to use immediately as a portable compressor. If using as a wall mounted compressor ensure the compressor is fully assembled.

USING THE AIR COMPRESSOR

Before starting run through this simple list:

1. Drain tap – open and drain tank
2. Drain tap – close fully
3. Check power lead for any damage. If damaged have replaced by an authorised service centre.
4. Plug air compressor into a standard 240V 10Amp AC power point and turn ON.
5. Push the switch to **I** to turn ON, see page 12, Pic. 6.
6. Allow the air compressor to fill the air tank.
7. Turn the air compressor OFF.
8. Turn the power point OFF and disconnect the power lead from the power point.
9. Connect your air hose and air tools.
10. Reconnect to the power lead to the power point and turn ON.
11. Turn your air compressor ON.

Note: Depending on the length of air hose used the air compressor may start immediately it is turned on due to the size of the tank.

12. You can begin using the connected air tools and the air compressor will start and stop without warning. This is controlled by the pressure switch. These pressure settings are factory set and should not be changed.

Pumping starts at (minimum) 85PSI and stops at (maximum) 115PSI. Once the initial pump up stage has finished you can adjust the outlet air pressure to the tools recommended working pressure and open the air tap fully.

PIC. 7



The configuration of tools and accessories can be varied to suit your particular requirements. A basic recommended set up is shown in Pic. 7 (accessories not included).

When you have finished using your air compressor follow these simple steps:

1. Turn your air compressor OFF, using the ON/OFF switch.
2. Turn the power point OFF and disconnect the power lead.
3. Disconnect your air tools and air hose.
4. Clean your air hose and air tools.
5. Store your air hose and air tools in a secure well ventilated cabinet.
6. Slowly open the tank drain tap, see page 16. This allows excess air and moisture, water, to vent.
7. Leave the tank drain tap open. This allows any moisture to drain while the air compressor is stored.

ADJUSTING THE PRESSURE

To adjust the outlet air pressure, use the red coloured regulator knob and check the pressure on the outlet pressure gauge, Pic. 8.

If the pressure needs to be lower, turn anti clockwise.

If the pressure needs to be higher, turn clockwise.

Use the gauge to ensure you set the correct working pressure.

Note: Different air tools require different operating pressures. Always check with the tool manufacturer if unsure.

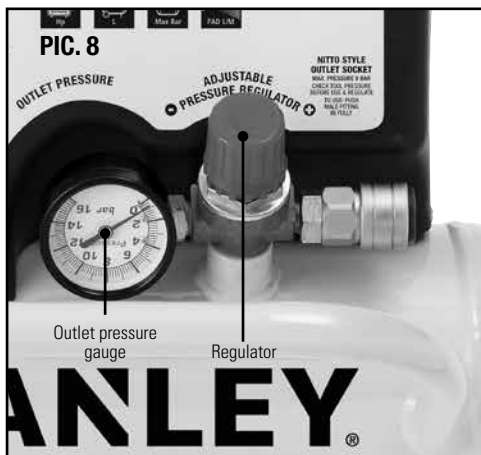

SAFETY VALVE

Pic. 9

NOTE: When checking the safety valve ALWAYS wear safety glasses.

To check the operation of the safety valve the air tank will need to be full.

Portable

Tip compressor backwards, the safety valve is located under the compressor. Gently pull the ring outwards. This should release air under pressure. Release the ring and when the pressure has dropped the air flow will stop. Note: there will still be some air left in the tank.

Wall Mounted

Remove compressor from the wall mounts. Place on stable ground or table. Then follow steps above under PORTABLE. Securely remount the compressor on the wall before using.

If the safety valve does NOT work in this manner, STOP the air compressor immediately and have the air compressor checked / serviced by an authorised service centre.

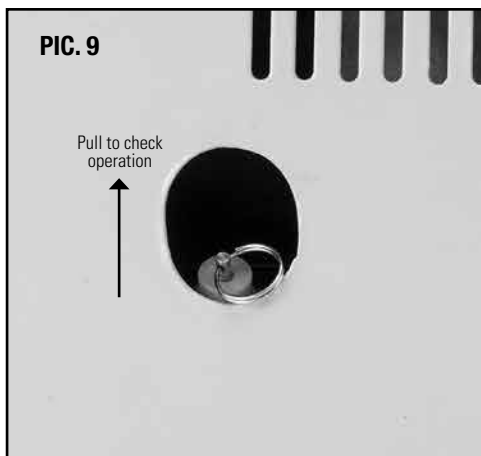

AIR TAP

Pic. 10

This air compressor is fitted with a 'Nitto style' socket.

To use:

1. Slide the outer collar down.
2. Push in the male plug (not included).
3. Release the collar.
4. Fully and completely push the male plug (not included) into the female socket until it clicks.

Note: This compressor has a maximum pressure of 8 bar. Always regulate the air pressure to match your air tool. Different air tools require different operating pressures. Always check with the tool manufacturer if unsure.

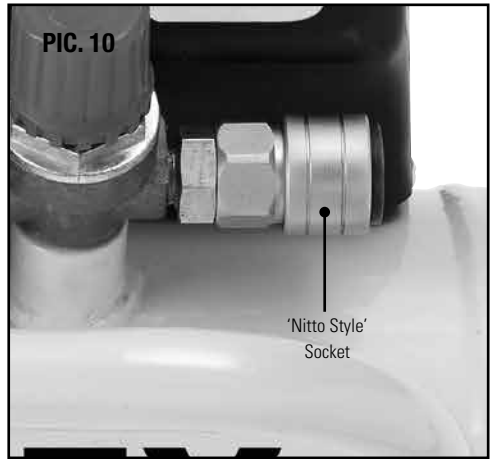

DRAIN TAP

Pic. 11 & 12

After use open the drain tap to drain excess air and any moisture. The excess air will also help purge the moisture. Leave the drain tap open when air compressor is not in use, so any moisture can continue to drain

To open the drain tap pull the lever down to vertical.

To seal the drain tap push the lever up to horizontal.

NOTE: Remember to seal the drain tap before starting the compressor.

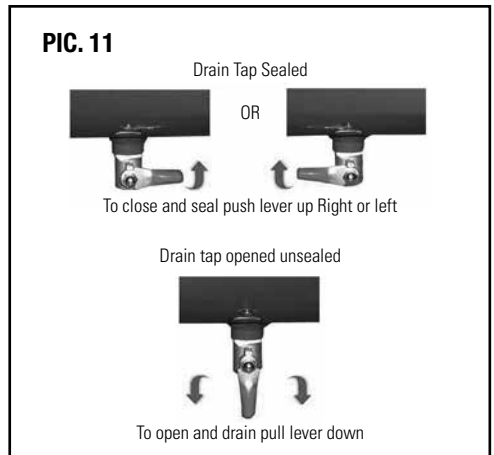

MAINTENANCE

Daily: Before Use

1. Seal the tank drain tap, see page 16, Pic. 11 & 12.
2. Check safety valve operation, see page 15, Pic. 9.

After Use

1. Open the tank drain tap, see page 16, Pic. 11 & 12.
2. Wipe down the air compressor.
3. Store safely and securely.



TROUBLE SHOOTING

If your compressor does not start

- Check that you have plugged the power lead into a standard 240V 10Amp power point and turned the switch ON.
- Check that you have turned the air compressor ON/OFF switch ON.
- The air tank may be full. Use your air tool and the air compressor should start when the pressure decreases to 85PSI.

If your compressor does not build up pressure

- Check that the tank drain tap is sealed.
- Check that the air fitting is not leaking. If leaking replace.

If your compressor smells like burnt oil

- Using beyond the 75% duty cycle, allow to cool for 30 minutes before reusing this air compressor.

Call SMG for your closest centre,

Aust. 1300 660 457 N.Z. 0800 474 876.

PARTS DIAGRAM



Part	Description	Qty	SMG Part No.
1	Output Regulator	1	95 AC6511REG
2	Outlet Pressure Gauge	1	95 AC6511OPG
3	Tank Pressure Gauge	1	95 AC6511TPG
4	Rubber Stopper with Bolt & Nut	1	95 AC6511RS
5	Drain Tap	1	95 AC6395DT
6	Nitto Style Socket Fitting	1	95 AC6395NSF
7	Motor Cover	1	95 AC6511MC
8	Storage Clip	1	95 AC6511WC
Part not shown	Safety Valve	1	95 AC6359SPV
Part not shown	Mounting Bracket with Screws	1	95 AC6511MB
Part not shown	Wall Mounting Bracket	1	95 AC6511WB

TECHNICAL INFORMATION

Specifications	
Air Compressor	AC6511
Voltage	240V AC ~ 50Hz
Motor	Electric 0.5Hp
Wattage	350W
	Oil free
No Load Speed	2800 RPM
Free Air Delivery (FAD)	14 L per minute*
Tank Size	5 L

SUGGESTED APPLICATIONS

You may use most light duty air tools with this compressor.

Some examples of light duty tools are;

- Ball Inflator
- Toy Inflator
- Tyre Inflator
- Mini Airbrush
- Stapler
- Combo Nailer

This light duty air compressor is NOT recommended for use with a spray gun or medium duty air tools.



For any queries or assistance call



Customer Service

AUST. 1300 660 457

NZ 0800 474 876

Hours of operation:

Monday to Friday 8.00am - 5.00pm AEST

Do not return to place of purchase.

Keep your purchase receipt, this will be required to
make any claims under the 24 month warranty.

STANLEY. STANLEY®

STANLEY, The STANLEY Logo, The Notched Rectangle and the
Yellow and Black Diagonal Package Design are all trademarks of
Stanley Black & Decker, Inc. or an affiliate thereof.