

# STANLEY®

## 23 LITRE WET/DRY VACUUM OWNER'S MANUAL

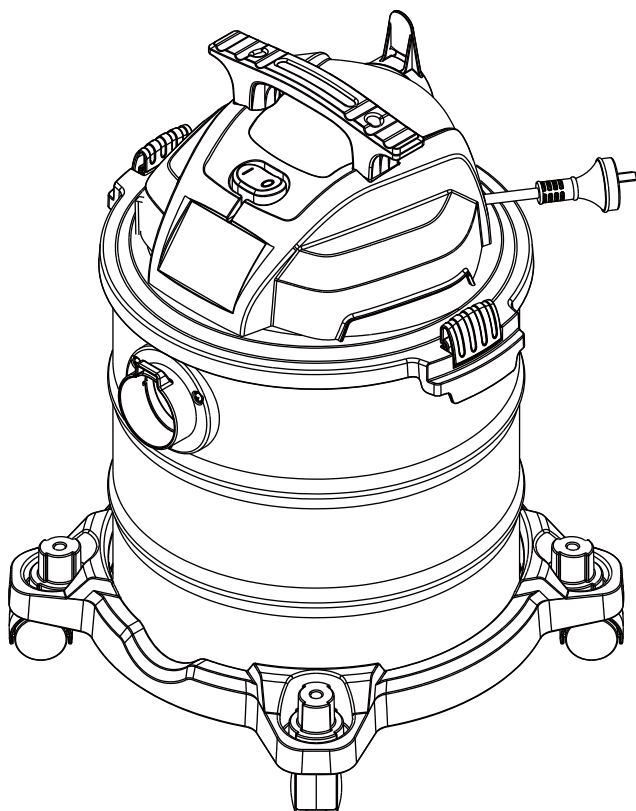

**IMPORTANT: READ THIS OPERATOR'S MANUAL  
BEFORE USING!**

Alton Industry Ltd. Group - All Rights Reserved

## TABLE OF CONTENTS

---

Specifications-----	3
Package Contents-----	4
Safety Information-----	5
Operating Instructions-----	7
Care and Maintenance -----	10
Troubleshooting-----	10
Exploded View and Parts List-----	11
Warranty-----	12

**To order replacement bag, filters or parts contact;**



Customer Service

**AUS 1300 660 457**

**NZ 0800 474 876**

**email: [service.group@smga.com.au](mailto:service.group@smga.com.au)**

---

## INTRODUCTION

Dear Customer,

Thank you for purchasing this wet/dry vacuum which has passed through our extensive quality assurance processes. Every care has been taken to ensure that it reaches you in perfect condition. However, in the unlikely event that you should experience a problem, or if you require any assistance please do not hesitate to contact us;

## PRODUCT SPECIFICATIONS

---

Power	240 V / 50 Hz / 1200W
Motor	By-Pass, Single Stage
Tank Capacity	23 Litre
Hose	1.8 m x 3.2 cm
Power cord	HVV05-F 2Cx0.75mm <sup>2</sup> / 3m

**⚠ WARNING:**

Use only extension cords that are rated for outdoor use. Extension cords in poor condition or that are too small in wire size can pose fire and shock hazards.

**⚠ If you have a problem, call customer service do not return this wet/dry vacuum to the place of purchase.**

**For any queries or assistance call**



Customer Service

**AUS 1300 660 457**  
**NZ 0800 474 876**

Hours of operation:  
Monday to Friday  
8.00am - 5.00pm AEST

**Do not return to place of purchase.**

Keep your purchase receipt, this will be required to make any claims under the 12 month warranty.

**Please take note of serial number and write here for ease of reference:**

**Serial Number:** \_\_\_\_\_

**Date of Purchase:** \_\_\_\_\_

**Place of Purchase:** \_\_\_\_\_

**Receipt Number:** \_\_\_\_\_

## PACKAGE CONTENTS

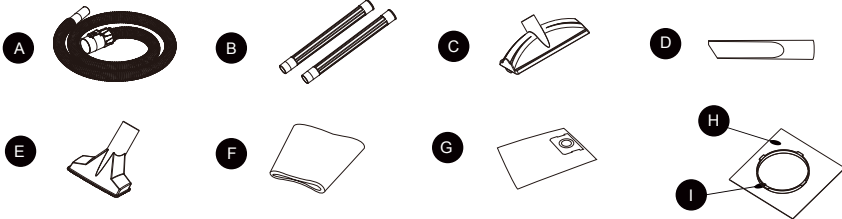
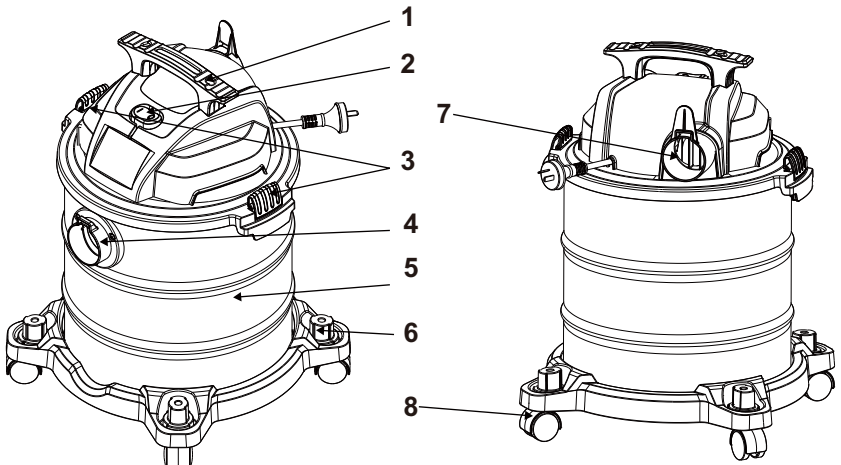

Part	Description	Qty
1	Handle	1
2	Power switch	1
3	Lid latches	2
4	Vacuum port	1
5	Dust tank	1
6	Base	1
7	Blowing port	1
8	Caster	4

Part	Description	Part No.	Qty
A	1.8 m x 3.2 cm hose	13-3300	1
B	Extension wand	13-1502A	2
C	Floor nozzle	13-1570	1
D	Crevice nozzle	13-1508	1
E	Gulper nozzle	13-1588	1
F	Foam filter	19-1600	1
G	Disposable filter bag	19-3100N	1
H	Resuable filter	19-1500N	1
I	Clamp ring	19-1500N	1

## SAFETY INFORMATION

---

### IMPORTANT SAFETY INSTRUCTIONS & GROUNDING INSTRUCTIONS

When using an electrical appliance, basic precautions should be always followed, including the following: **READ ALL INSTRUCTIONS BEFORE USING THIS APPLIANCE.**

#### **ATTENTION:**

Read all safety rules carefully before attempting to operate. Retain for future reference.

#### **DANGER:**

Never operate this unit when flammable materials or vapors are present because electrical devices produce arcs or sparks that can cause a fire or explosion.

**NEVER LEAVE OPERATING VACUUM UNATTENDED:**

#### **WARNING:**

**To reduce the risk of fire, electric shock, or injury:**

1. Do not leave appliance when plugged in. Unplug from outlet when not in use and before servicing. Connect to a properly grounded outlet only. See Grounding Instructions.
2. Do not expose to rain. Store indoors.
3. Always disconnect the plug from the wall outlet before removing the tank cover.
4. Do not allow to be used as a toy. Close attention is necessary when used by or near children.
5. Do not use with damaged cord or plug. If appliance is not working as it should, has been dropped, damaged, left outdoors or dropped into water, contact service center for assistance.
6. Do not: pull or carry by cord, use cord as a handle, close a door on cord or pull cord around sharp edges or corners. Do not run appliance over cord. Keep cord away from heated surfaces.
7. Do not unplug by pulling on cord. To unplug, grasp the plug, not the cord.
8. Do not handle plug or appliance with wet hands.
9. Do not put any object into openings. Do not use with any openings blocked; keep free of dust, lint, hair and anything that may reduce air flow.
10. Keep hair, loose clothing, fingers and all parts of body away from openings and moving parts.
11. Do not pick up anything that is burning or smoking, such as cigarettes, matches or hot ashes.
12. Do not use without dust bag and/or filters in place.
13. Turn off all controls before unplugging.
14. Use extra care when cleaning on stairs.
15. Do not use to pick up flammable or combustible liquids such as gasoline or use in areas where they may be present.
16. Do not use the cleaner as a sprayer of flammable liquids such as oil-based paint, lacquers, etc.
17. Do not vacuum toxic, carcinogenic, combustible or other hazardous materials such as asbestos, arsenic, barium, beryllium, lead, pesticides or other health endangering materials.
18. Do not pick up soot, cement, plaster or drywall dust without filter and dust bag in place. These are very fine particles that may affect the performance of the motor or be exhausted back into the air. Additional dust bags are available.
19. Do not leave the cord lying on the floor once you have finished the cleaning job. It can become a tripping hazard.
20. Use special care when emptying heavily loaded tanks.
21. To avoid spontaneous combustion, empty tank after each use.
22. The operation of a utility vac can result in foreign objects being blown into eyes, which can result in eye damage. Always wear safety goggles when operating vacuum.
23. **STAY ALERT.** Watch what you are doing and use common sense. Do not use vacuum cleaner when you are tired, distracted or under the influence of drugs, alcohol or medication causing diminished control.

NOTE: Use only as described in this manual. Use only manufacturer's recommended attachments.

## SAFETY INFORMATION

---

24. This appliance is provided with double insulation. Use only identical replacement parts. See instructions for servicing double insulated appliances.
25. Unplug before connecting the hose, nozzle and the like.

### WARNING:

#### **SERVICING OF DOUBLE-INSULATED WET/DRY VAC**

In a double-insulated Wet/Dry Vac, two systems of insulation are provided instead of grounding. No grounding means is provided on a double-insulated appliance, nor should a means for grounding be added. Servicing a double-insulated Wet/Dry Vac requires extreme care and knowledge of the system and should be done only by qualified service personnel. Replacement parts for a double-insulated Wet/Dry Vac must be identical to the parts they replace. The double-insulated Wet/Dry Vac is marked with the words "DOUBLE INSULATED" and the symbol  (square within a square) may also be marked on the appliance.

To reduce the risk of injury from electrical shock, unplug power cord before servicing the electrical parts of the Wet/Dry Vac.

#### **IMPORTANT!**

If the supply cord is damaged, it must be replaced by the manufacturer or its service agent or a similarly qualified person in order to avoid a hazard.

#### **IMPORTANT!**

Remove the plug from the socket before performing maintenance. Before using the machine make sure that the frequency and voltage shown on the rating plate correspond with the mains voltage. Specifications and details are subject to change without prior notice. The accessories shown in the pictures may vary from model to model.

#### **IMPORTANT SAFEGUARDS**

The symbol on the product or packaging indicates that the product must not be treated as domestic refuse. Instead, it should be handed in to a collection point for the recycling of electrical and electronic components. By ensuring the product is treated in the correct manner, you will help prevent any negative impact on the environment and health that might arise were the product to be discarded as ordinary refuse. For further information about recycling, you should contact your local authorities, refuse collection service or the sales outlet where you bought the goods.



### WARNING:

This product is NOT to be used for filtering of pathogens, for example COVID-19. Follow all local, state and federal guidance on general cleaning practices.

## OPERATING INSTRUCTIONS

### UNPACKING & SET-UP SUMMARY

1. Pull lid latches in an outward motion, remove power head and some accessories that may have been shipped in the tank.
2. Attach the casters according to the instruction in this manual.
3. Before replacing power head, refer to this manual to ensure you have the proper filters installed for your cleaning operation.
4. Replace power head, and apply pressure with thumb to each latch until it snaps tightly in place. Make sure all lid latches are clamped securely.
5. Insert the flexible hose end into inlet of tank.
6. Attach the extension wands to the accessory end of the hose. Apply slight pressure until fitting is tight.
7. Attach one of the cleaning accessories (depending on your cleaning requirements) on the extension wands. Twist slightly to tighten the connection.
8. Plug the cord into the wall outlet. The vacuum is ready for use.

### CASTER ASSEMBLY

- Insert casters into dolly and snap them into place.

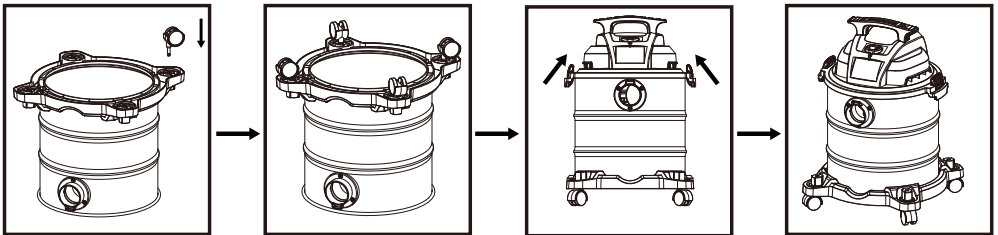

#### **⚠ WARNING:**

To reduce the risk of fire or explosion, do not operate this vac in areas with flammable gases, vapors or explosive dust in the air. Flammable gases or vapors include but are not limited to: lighter fluid, solvent-type cleaners, oil-based paints, gasoline, alcohol or aerosol sprays. Explosive dusts include but are not limited to: coal, magnesium, aluminum, and grain or gun powder. Do not vacuum explosive dust, flammable or combustible liquids or hot ashes. Do not use this vac as a sprayer for any flammable or combustible liquid. To reduce the risk of health hazards from vapors or dusts, do not vacuum toxic materials.

#### **⚠ WARNING:**

The operation of any utility vac can result in foreign objects being blown into the eyes, which can result in severe eye damage. Always wear safety eyewear complying with ANSI Z87.1 in USA or CSA Z94.3 in Canada before starting operation.

#### **⚠ CAUTION:**

To reduce risk of hearing damage, wear ear protectors when using the vac for extended hours or when using it in a noisy area.

This vac is assembled at the factory and ready for use when you remove it from the carton. The unit is ready for dry vacuuming or blowing. After you plug the power cord into the wall receptacle, turn the unit "ON" by pushing the switch from position "O" to position "I". The "O" is the "OFF" position and the "I" is the "ON" position.

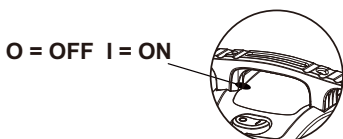

## **OPERATING INSTRUCTIONS**

### **DRY PICK-UP**

1. The filter must always be in correct position to reduce the risk of leaks and possible damage to vac. Make sure that the filter is completely covering the filter cage. Make sure there are no gaps between the filter and the lid. (See illustration). It is very important to assemble the filter to the cage without allowing any possible leaks or tears. Any leaks will allow the picked up debris to be blown out of the blowing port and back into the surrounding environment.
2. When using the vac to pick up very fine dust, it will be necessary to empty the dust tank and clean or replace the filter at more frequent intervals to maintain peak vac performance.

### **NOTE:**

A dry filter is necessary to pick up dry material. If you use the vac to pick up dust when the filter is wet, the filter will clog quickly and be very difficult to clean. If the filter gets wet, replace it before continuing to do dry pickups.

### **INSTALLING DISPOSABLE FILTER BAG**

1. Slide the cardboard collar opening firmly onto the vacuum port deflector until it stops against the deflector wall.
2. Position the bag so that it is distributed around the inside of the tank.
3. Replace and secure the power head onto the tank.

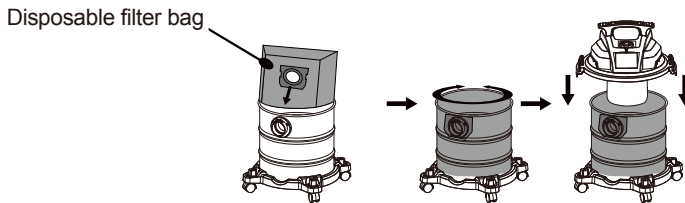

### **WET PICK-UP**

1. Remove reusable filter and replace it with foam filter when you do wet pickups.
2. This wet/dry vac is equipped with a float mechanism which will rise automatically to cut off the airflow when the liquid in the tank reaches a predetermined level. When this happens, turn off vac, unplug the power cord, and empty the dust tank. You will know that the float has shut the airflow off because the suction ceases and the motor noise becomes higher in pitch due to increased motor speed. The liquid capacity may vary with the rate of pickup.

**IMPORTANT:** To reduce the risk of damage to the vac, do not run motor with float in raised position.

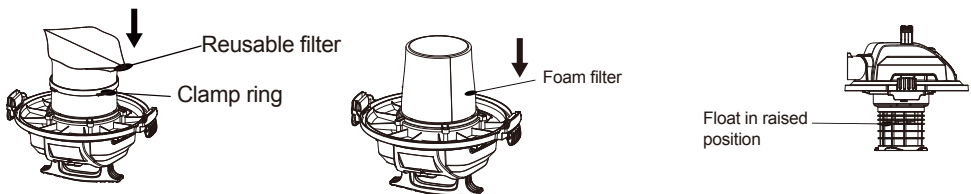



## OPERATING INSTRUCTIONS

---

### EMPTY THE TANK

#### **⚠ WARNING:**

To reduce the risk of injury from accidental starting, unplug power cord before emptying the dust tank.

1. Remove the power head assembly of the wet/dry vac by pulling outward on the lid clips located on each side of the vac. Lift off the power head assembly. Dump the tank contents into the proper waste disposal container.

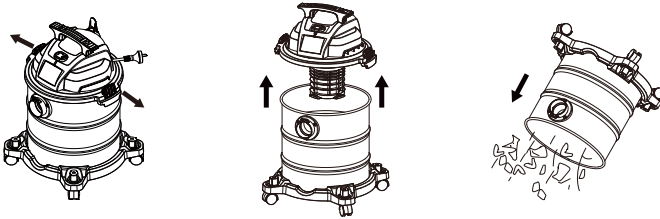

### BLOWING OPERATION

- ⚠ WARNING:** Always wear safety eyewear complying with ANSI Z87.1 in USA or CSA Z94.3 in Canada when using as a blower.
- ⚠ WARNING:** To avoid injury to bystanders, keep them clear of blowing debris.
- ⚠ CAUTION:** Wear a dust mask if blowing creates dust which might be inhaled.
- ⚠ CAUTION:** To reduce the risk of hearing damage, wear ear protectors when using the vac/blower for extended hours or when using it in a noisy area.

The vac contains a blowing feature. It has the capability to blow sawdust and other debris. It can be used to blow dust and debris out of garages or off patios and driveways. Follow the steps below to use the vac as a blower.

1. Locate blowing port on the vac.
2. Insert one end of the hose into the blowing port.
3. Turn vac "ON".

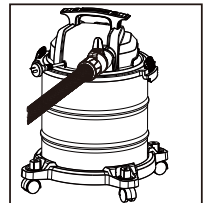

## CARE AND MAINTENANCE

---

### FILTER REPLACEMENT

**⚠ WARNING:** To reduce the risk of injury from accidental starting, unplug power cord before changing or cleaning filter.

The filter should be cleaned often to maintain peak vac performance.

**IMPORTANT:** To avoid damage to the blower wheel and motor, always reinstall the reusable filter before using the vac for dry pickups and always reinstall the foam filter before using the vac for wet pickups.

**IMPORTANT:** After cleaning, check the filter for tears or small holes. Do not use a filter with holes or tears in it. Even a small hole can cause a lot of dust to come out of the vac. Replace it immediately.

**NOTE:** Before installing the filter on the vac, clean the area of the lid so that the clamp ring will seal the bag against the lid and stop small particles from bypassing the filter bag.

If the filter is clean and not damaged, replace it on the filter cage. If it cannot be reused, place a new filter over the filter cage.

#### NOTE:

Clean the filter in an open area. Cleaning should be done outdoors and not in living quarters.

**⚠ WARNING:** Do not remove filter cage and float. The float prevents water from entering the impeller and damaging the motor. The cage prevents fingers from touching the moving impeller.

### CLEANING

To keep the wet/dry vac looking its best, clean the outside with a cloth dampened with warm water and mild soap.

To clean the tank:

1. Dump out debris.
2. Wash tank thoroughly with warm water and mild soap.
3. Wipe out with dry cloth.

### STORAGE

Before storing the vac, the dust tank should be emptied and cleaned. The cord should be wrapped and hung on the unit and the accessories should be kept in the accessory holder so they can be readily available. The vac should be stored indoors.

## TROUBLESHOOTING

---

### **⚠ WARNING!**

**TO REDUCE THE RISK OF INJURY FROM MOVING PARTS AND/OR ELECTRICAL SHOCK, TURN POWER SWITCH OFF AND DISCONNECT GROUNDED PLUG FROM ELECTRICAL OUTLET BEFORE PERFORMING TROUBLESHOOTING CHECKS.**

Minor problems often can be fixed without calling customer service.

PROBLEM	POSSIBLE CAUSE	CORRECTIVE ACTION
Vacuum will not run	No electricity	Make sure electrical outlet has voltage (A qualified electrician may need to be contacted)
Loss of suction, wet pick-up	1. Full tank 2. Clogged hose 3. Clogged filter	1. Drain and clean tank 2. Remove hose and clean debris 3. Clean or replace filter
Loss of suction, dry pick-up	1. Full tank 2. Clogged hose 3. Clogged filter	1. Drain and clean tank 2. Remove hose and clean debris 3. Clean or replace filter

**EXPLODED VIEW / PARTS LIST**

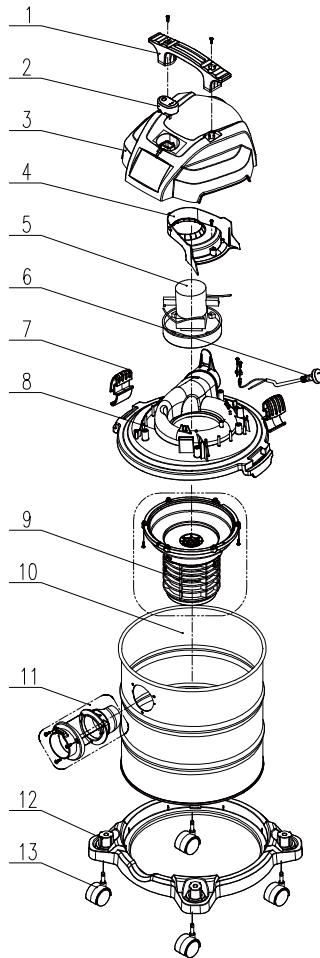

PART	DESCRIPTION	QTY
1	Handle	1
2	Power switch	1
3	Top cover	1
4	Thermal baffle	1
5	Motor	1
6	Power cord	1
7	Lid latches	2

PART	DESCRIPTION	QTY
8	Middle frame	1
9	Pallet components	1
10	Dust tank	1
11	Vacuum port assembly	1
12	Base	1
13	Caster	4

## **WARRANTY**

---

### **EXPRESS WARRANTY STATEMENT WET/DRY VACUUM**

You are not required to do anything to register the wet/dry vacuum purchase. Please attach the purchase receipt to this manual and ensure both are kept safe. We hope you enjoy the new wet/dry vacuum, and if you have any problems call customer service on the above phone numbers. Do not return to place of purchase.

Smart Marketing Group Pty Ltd (SMG) warrants that this wet/dry vacuum will be free from manufacturing faults or defects for 12 months from the date of purchase, providing original purchase receipt is kept and shown when needed and is subject to the terms and conditions below.

If a warranty fault appears within the warranty period, SMG reserves the right to replace or repair the product. In the event that SMG chooses to replace the product, this original warranty will expire at the original date. If the product includes various accessories or components, only the defective accessory or component will be replaced or repaired. SMG reserves the right to replace defective parts of the product with parts and components of similar quality, grade and composition where an identical part or component is not available. Products presented for repair may be replaced by refurbished products of the same type rather than being repaired. Refurbished parts may be used to repair the products.

#### **WHAT IS COVERED**

- Manufacturing fault or defect.

#### **HOW TO CLAIM UNDER THIS WARRANTY**

- Call customer service.
- Ensure you have the following: Original purchase receipt, Model of wet/dry vacuum, Serial number of wet/dry vacuum.
- Discuss the issue.
- Customer service will advise which authorised service agent to take the wet/dry vacuum to provided the issue is a warranty one.
- Take wet/dry vacuum to authorised service agent for repair.

#### **WHAT IS NOT COVERED**

- Use of wet/dry vacuum for hire.
- Commercial use of wet/dry vacuum.
- Use of wet/dry vacuum in a commercial application.
- Damage or deterioration due to transport.
- Damage caused by negligence, misuse, abuse or accident or incorrect voltage and wattage.
- Any corrosion or rusting.
- Damage caused by incorrect set up and start up.
- Replacement parts due to general wear and tear.
- Wet/dry vacuum with serial number defacement, modification or removal.
- Wet/dry vacuum which have been serviced by other than an authorised SMG service agent.
- Wet/dry vacuum with no original purchase receipt.
- Wet/dry vacuum which have been on sold, not original purchaser.
- Damage due to non-servicing of wet/dry vacuum as is required by this manual.
- Blockages / damage caused by dust, dirt, spiders webs or insects.
- Damage caused by the incorrect fitting of accessories.
- Damage caused by overloading, overworking the wet/dry vacuum.
- Damage to attached equipment or third party accessories.
- Damage caused by attached equipment or third party accessories.

#### **CONTACT DETAILS**

Smart Marketing Group Pty Ltd  
33-35 Lionel Road, Mt. Waverley,  
Victoria 3149, Australia.  
AUS 1300 660 457  
NZ 0800 474 876  
service.group@smga.com.au

## **WARRANTY**

---

### **COMPLETE WARRANTY STATEMENT – WET/DRY VACUUM**

As soon as you have purchased the wet/dry vacuum, we recommend that you check to make sure it is intact and that you read the operating instructions carefully before using it. The purchase receipt for this product is to be retained and must be presented if making a claim under the terms of the Smart Marketing Group (SMG) warranty. Bank account statements are not acceptable for proof of purchase.

This warranty does not cover wet/dry vacuum intended for hire or use in commercial applications or in commercial premises. The warranty will under no circumstances extend to reimbursement or payment of damages, whether direct, indirect or consequential.

The warranty is void if there is evidence the wet/dry vacuum has been modified or tampered with in any way or used with unauthorised accessories without our consent.

SMG declines any responsibility or liability whatsoever arising from misuse or abuse, negligent handling of the wet/dry vacuum or if the product has not been installed or failure to comply with the relevant safety, operating, setting and maintenance instructions (see further in this manual). The warranty does not extend to installation or disconnection costs.

Any item sent freight forward/collect for repair will be refused. Warranty repairs are free of charge, provided the product is delivered to our service department or authorised service agent. The wet/dry vacuum will need to be returned, adequately protected in a box. SMG will not be responsible for any in-transit loss or damage. Assistance under the warranty will only be made available if the request is made to our customer service team on the contact numbers listed below and proof of purchase is provided.

This is a repair only warranty you will need to take the wet/dry vacuum to the authorised service agent after contacting our customer service centre.

If the product includes various accessories or components, only the defective accessory or component will be replaced or repaired.

SMG reserves the right to replace defective parts of the product with parts and components of similar quality, grade and composition where an identical part or component is not available.

Products presented for repair may be replaced by refurbished products of the same type rather than being repaired. Refurbished parts may be used to repair the products.

Damage caused by third party accessories is not covered under this warranty. Damage caused to attached equipment or third party accessories will not be covered under this warranty. Rust and corrosion are not covered under this warranty.

If a warranty fault is found the freight cost will be credited to the owner. If no fault is found the product will be returned and any costs associated with the service will be charged to the owner.

Blockages caused by spider webs, insects, dirt, accumulated dust, incorrect voltage and wattage are not covered by this warranty.

SMG reserves the right to replace or repair the product within the warranty period. Parts found to be defective due to a manufacturing fault will be replaced free of charge.

In the event of SMG choosing to replace the product, the warranty will expire at the original date of purchase. If no warranty fault is found the owner will be advised and the product will be returned and any costs associated with the service will be charged to the owner.

Our goods come with guarantees that cannot be excluded under the Australian Consumer Law. You are entitled to a replacement or refund for a major failure and for compensation for any other reasonably foreseeable loss or damage. You are also entitled to have the goods repaired or replaced if the goods fail to be of acceptable quality and the failure does not amount to a major failure. The benefits of this warranty are in addition to any rights and remedies imposed by Australian State and Federal legislation that cannot be excluded.

In New Zealand, this SMG warranty is in addition to the conditions and guarantees which are mandatory as implied by the New Zealand Consumer Guarantee Act 1993. For service, spare parts or product information please contact customer service:

Australia: 1300 660 457

New Zealand: 0800 474 876

Do not return to place of purchase.

Smart Marketing Group Pty Ltd

Customer Service

Australia: 1300 660 457

New Zealand: 0800 474 876

Operating times: Monday – Friday 8.00am - 5.00 pm

Australian Eastern Standard Time (AEST)

33-35 Lionel Road, Mt. Waverley

Victoria 3149, Australia.

Stanley® and **STANLEY** are trademarks of Stanley Black & Decker, Inc.,  
or its affiliates and are used under license by Alton Industry Ltd. Group

The Stanley Black & Decker, Inc.

New Britain, CT 06053 U.S.A

<http://www.stanleyblackanddecker.com>