

STANLEY®

Water Transfer Pumps



WT50, WT75

Pump

- Engineering plastic pump body
- Max. fluid temperature: +35°C
- Max. suction: +8m

Motor

- Built-in thermal protector
- Aluminium winding
- Insulation class: F
- Protection class: IPX4
- Max. ambient temperature: +40°C

Hydraulic performance curve

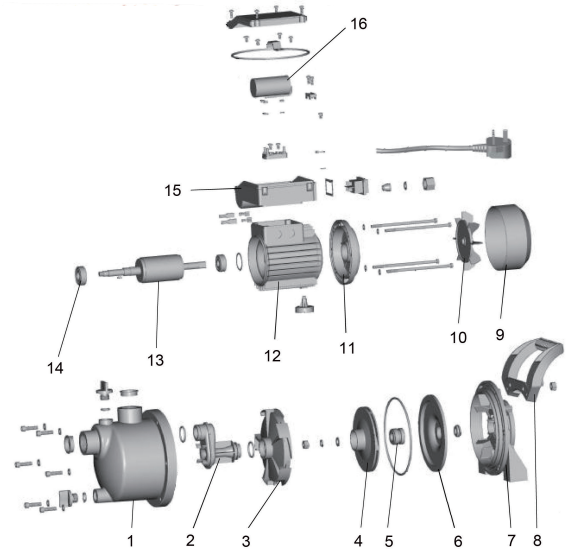
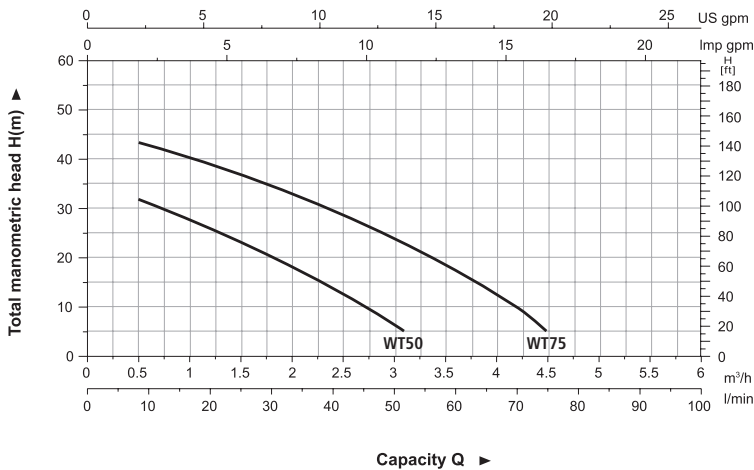

Part		Part	
1	Pump body	9	Fan cover
2	Venturi tube	10	Fan
3	Diffuser	11	Rear cover
4	Impeller	12	Stator
5	Mechanical seal	13	Rotor
6	Support cover	14	Bearing
7	Support	15	Terminal box
8	Handle	16	Capacitor

Model	Power		Inlet/outlet	Max. flow (L/min)	Max. head (m)	Max. Suct. (m)
	(W)	(HP)				
WT50	600	0.8	1"x1"	50	35	8
WT75	1100	1.5	1"x1"	77	46	8